

# Operating and Installation Instructions

Avigilon High Definition IP Dome Camera Indoor In-Ceiling Mount DOME-IND-CEL

---

Avigilon Corporation  
Vancouver, BC  
Canada, V6H 4E4

TEL 604.629.5182  
FAX 604.629.5183

[avigilon.com](http://avigilon.com)



# Installation

## Installation Steps

Follow these steps to install the indoor in-ceiling mount. Details on how to complete each of these steps are in the following sections.

1. Check the package contents against the list below.
2. Mount the indoor in-ceiling mount.
3. Mount the dome camera.

### Package Contents

The package contains the following:

- Avigilon High Definition IP Dome Camera Indoor In-Ceiling Mount
- 3 x Screw for Mounting Dome
- Hole Template

## Mounting the Indoor In-Ceiling Mount

To mount the indoor in-ceiling mount, complete the following steps:

1. Locate the position in the ceiling for a 180 mm (7") hole to be cut. A hole template is included to aid in cutting the mounting hole.
2. Remove the in-ceiling cover and three screws from the in-ceiling mount.
3. Insert the in-ceiling mount into the hole.

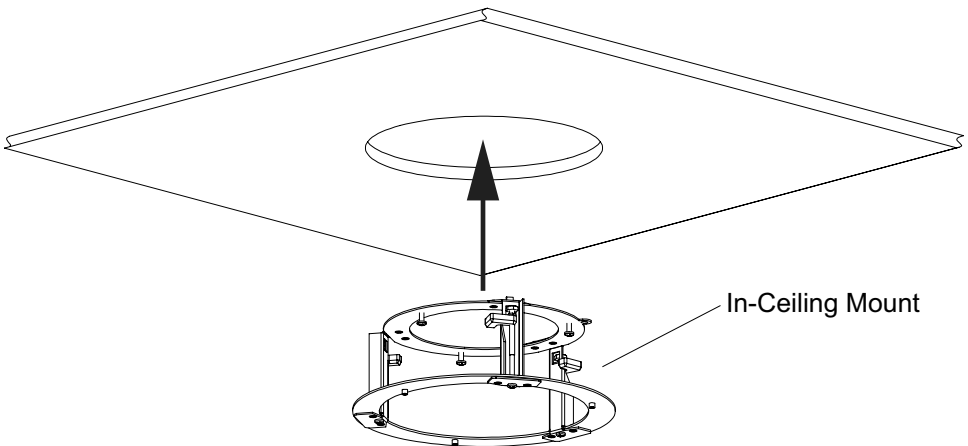

**Figure:** Indoor In-Ceiling Mount Installation

4. Tighten the three clamping screws until the mount is secure. Over tightening the clamping screws may cause damage to the ceiling or the in-ceiling mount.

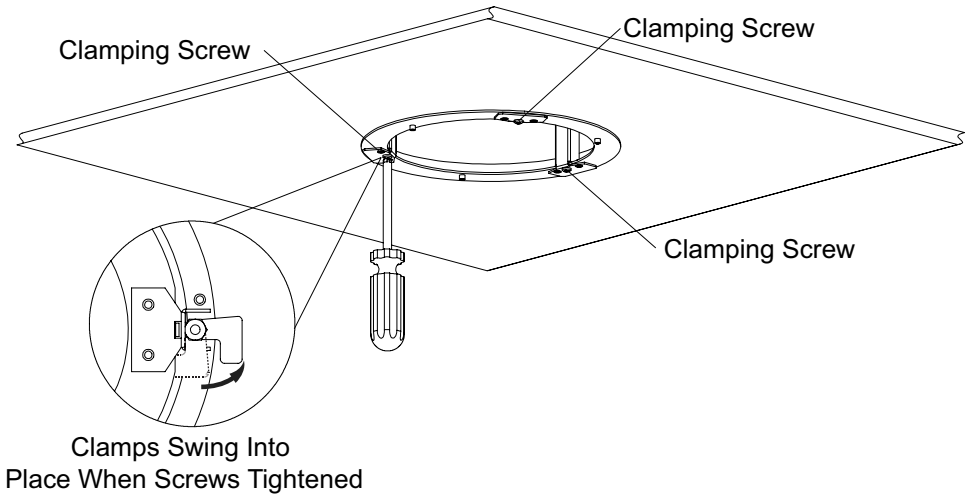

**Figure:** Indoor In-Ceiling Mount Installation

5. Attach a safety chain/cable (not supplied) to the in-ceiling mount that will support the combined weight of the dome camera and the in-ceiling mount (1.8 kg [4.0 lbs]).



**Caution**

- The ceiling material must be sturdy enough to hold the combined weight of the dome camera and the in-ceiling mount (1.8 kg [4.0 lbs]).
  - This mount is designed for indoor use only.
-

## Mounting the Dome Camera

To mount the dome camera, complete the following steps:

1. Drive the three supplied screws into the holes inside the in-ceiling mount and leave 6 mm (1/4") between the screw head and the surface.
2. Pull the cables through the top of the in-ceiling mount and the cable entry hole in the dome camera.
3. Place the dome base on the screws using the keyed mounting slots and rotate it clockwise.
4. Tighten the screws to hold the dome camera in place.
5. Finish the installation of the dome camera according to the dome camera installation instructions.

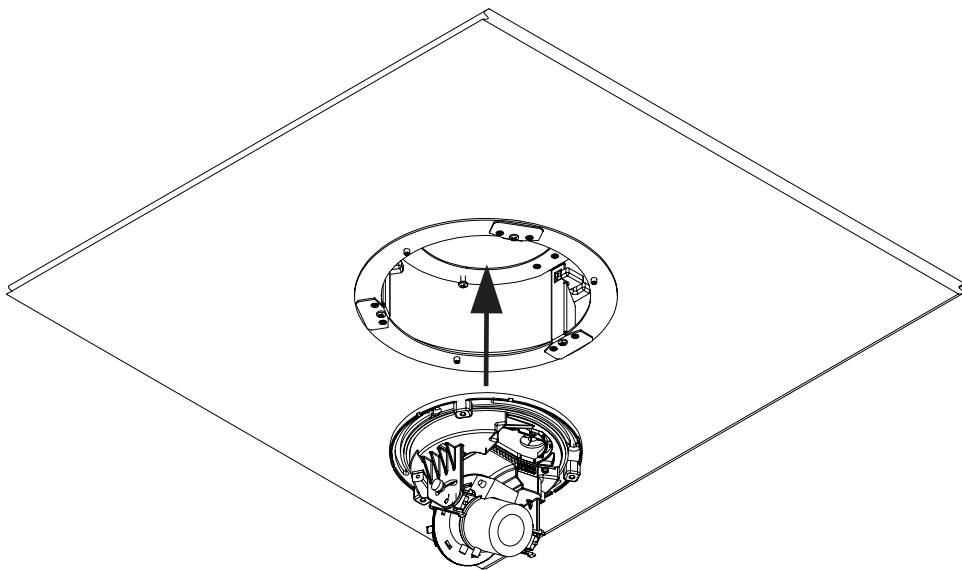

**Figure:** Dome Camera Installation

- 6. Mount the in-ceiling cover to the in-ceiling mount using the three screws supplied with the cover.

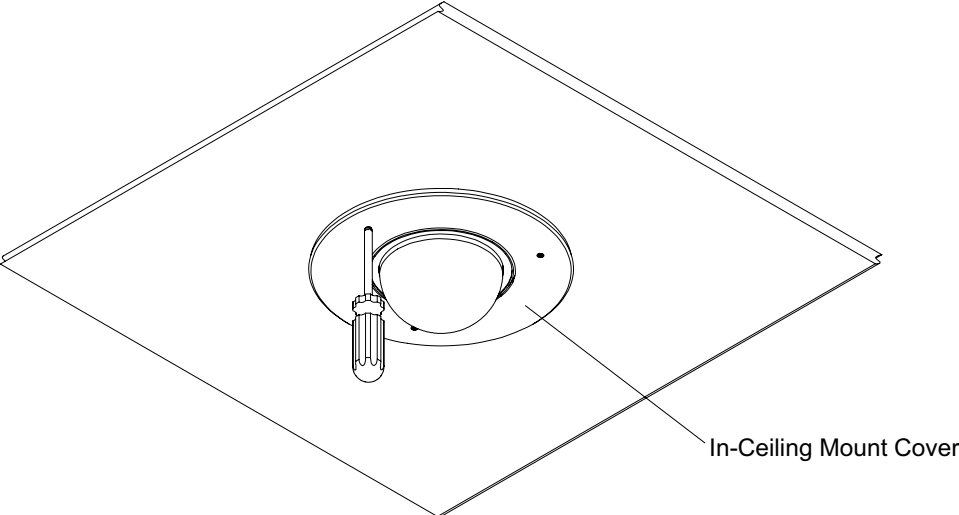

**Figure:** In-Ceiling Cover Installation

# Limited Warranty & Technical Support

Avigilon warrants to the original consumer purchaser, that this product will be free of defects in material and workmanship for a period of 3 years from date of purchase. The manufacturer's liability hereunder is limited to replacement of the product, repair of the product or replacement of the product with repaired product at the discretion of the manufacturer. This warranty is void if the product has been damaged by accident, unreasonable use, neglect, tampering or other causes not arising from defects in material or workmanship. This warranty extends to the original consumer purchaser of the product only.

AVIGILON DISCLAIMS ALL OTHER WARRANTIES EXPRESSED OR IMPLIED INCLUDING, WITHOUT LIMITATION, ANY IMPLIED WARRANTIES OF MERCHANTABILITY OR FITNESS FOR A PARTICULAR PURPOSE, EXCEPT TO THE EXTENT THAT ANY WARRANTIES IMPLIED BY LAW CANNOT BE VALIDLY WAIVED.

No oral or written information, advice or representation provided by Avigilon, its distributors, dealers, agents or employees shall create another warranty or modify this warranty. This warranty states Avigilon's entire liability and your exclusive remedy against Avigilon for any failure of this product to operate properly.

In no event shall Avigilon be liable for any indirect, incidental, special, consequential, exemplary, or punitive damages whatsoever (including but not limited to, damages for loss of profits or confidential or other information, for business interruption, for personal injury, for loss of privacy, for failure to meet any duty including of good faith or of reasonable care, for negligence, and for any other pecuniary or other loss whatsoever) arising from the use of or inability to use the product, even if advised of the possibility of such damages. Since some jurisdictions do not allow the above limitation of liability, such limitation may not apply to you.

This Limited Warranty gives you specific legal rights and you may also have other rights which vary from jurisdiction to jurisdiction.

**Warranty service and technical support can be obtained by contacting Avigilon Technical Support by phone at 1.888.281.5182 or via email at [support@avigilon.com](mailto:support@avigilon.com).**







This page is intentionally left blank.

**avigilon**  
THE BEST EVIDENCE™

©2008 Avigilon Corporation  
V1.0